

## CV730-BK/WH Visca over RS232 & IP Command Set

### 1. Communication Protocol

Transmit Method: Asynchronous Interface Half  
Duplex Serial Communication

- Transmit Speed: 9600bps or 38400bps
- Start bit: 1Bit
- Parity Check: NA
- Data Bit: 8Bit
- Stop Bit: 1Bit

### 2. The wire diagram.

The RS232 wire diagram between presenter and remote controller as below

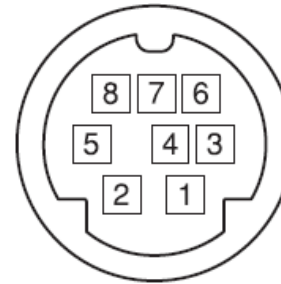

No	Pins
1	DTR IN
2	DSR IN
3	TXD IN
4	GND
5	RXD IN
6	GND

## 1 ACK & Completion message

	Reply Packet	Note
Ack	X0 4Y FF	Y = socket number
Completion (commands)	X0 5Y FF	Y = socket number
Completion (Inquiries)	X0 50 ... FF	
X = 9 to F==>camera address + 8 , Y=1 to 2		

## 2 Error message

Error Packet	Description
X0 6Y 02 FF	Syntax Error
X0 6Y 03 FF	Command buffer full
X0 6Y 04 FF	Command cancelled
X0 6Y 05 FF	No socket (to be cancelled)
X0 6Y 41 FF	Command not executable
X = 9 to F==>camera address + 8, Y = socket number, Y=0 to 2, 0: Inquiry not execution	

## 3 Command execution cancel

	Cancel Packet	Note
Cancel	8X 2Y FF	Y = socket number
X = 1 to 7==>camera address, Y = socket number, Y=1 to 2		

## 4 Network Change

	Packet	Note
Address set	88 30 01 FF	Always broadcasted(Reply:88 30 0w FF w:1+Address)
Network Change	X0 38 FF	
X = 9 to F==>camera address + 8		

## 5 IF\_Clear

	Command	Reply Packet Note
IF_Clear	8X 01 00 01 FF	X0 50 FF
IF_Clear (broadcast)	88 01 00 01 FF	88 01 00 01 FF
X = 1 to 7==>camera address (For inquiry packet)		
X = 9 to F==>camera address +8 (For reply packet)		

## 6 Zoom Focus Position Table

Zoom Position	Wide end		Tele end
	0000	to	4000
Focus Position	Far end		Near end
	000	to	969

## 7 AE\_Iris Table

	Index(pq)	Value
Iris	0F	Close
	0E	F1.6
	0D	F2
	0C	F2.2
	0B	F2.7
	0A	F3.2
	09	F3.8
	08	F4.5
	07	F5.4
	06	F6.3
	05	F7.8

	04	F9
	03	F11
	02	F13
	01	F16
	00	F18

## 8 AE\_Shutter Table

Shutter Speed	Index(pq)	60/30 mode	50/25 mode
	00	1/10000	1/10000
	01	1/5000	1/5000
	02	1/3000	1/3000
	03	1/2500	1/2500
	04	1/2000	1/1750
	05	1/1500	1/1250
	06	1/1000	1/1000
	07	1/725	1/600
	08	1/500	1/425
	09	1/350	1/300
	0A	1/250	1/215
	0B	1/180	1/150
	0C	1/120	1/120
	0D	1/100	1/100
	0E	1/90	1/75
	0F	1/60	1/50
	10	1/30	1/25
	11	1/15	1/12
12	1/8	1/6	

	13	1/4	1/3
	14	1/2	1/2
	15	1/1	1/1

## 9 AE\_Gain Table

Gain	Index(pq)	Value
	0F	+45 dB
	0E	+42 dB
	0D	+39 dB
	0C	+36 dB
	0B	+33 dB
	0A	+30 dB
	09	+27 dB
	08	+24 dB
	07	+21 dB
	06	+18 dB
	05	+15 dB
	04	+12 dB
	03	+9 dB
	02	+6 dB
	01	+3 dB
00	0 dB	

## 10 AE\_Exposure Comp. Table

Exposure Comp.	Index(pq)	Value(Level)	(Gain)Value
	0A	5	+8.0 dB
	09	4	+6.4 dB
	08	3	+4.8 dB
	07	2	+3.2 dB
	06	1	+1.6 dB
	05	0	0 dB
	04	-1	-1.6 dB
	03	-2	-3.2 dB
	02	-3	-4.8 dB
	01	-4	-6.4 dB
	00	-5	-8.0 dB

## 11 Others

Parameter	Range
R Gain	00 to 80
B Gain	00 to 80

## 12 Camera RS232 Command List

Command Set	Command	Command Packet	Comments
Audio	Audio Enable	8x 01 04 68 0p FF	p: 2=On, 3=Off
	Delay Time	8x 01 04 6A 0p 0q 0r FF	Set AudioDelay Time for Internet Streaming pqr : delay time, range: 001 ~ 1F4 (1 ~ 500)
	Audio In	8x 01 04 6B 0p FF	p: 2=Line In, 3=Mic In
	Encode Sample Rate	8x 01 04 6D 0p FF	Select Audio Encode Sample Rate p: 0=48 KHz (AAC), 1=44.1 KHz (AAC), 2=16 KHz (AAC), 3=16 KHz (G.711), 4=8 KHz (G.711)
	Audio Volume	8x 01 04 6E 0p FF	p: 0 ~ A (0 ~ 10)
	Delay Enable	8x 01 04 6F 0p FF	Set AudioDelay On/Off for Internet Streaming p: 2=On, 3=Off
Auto Focus	Zoom Tracking	8x 01 04 38 03 0p FF	p: 2=Off (Curve Tracking), 3=On (Zoom Tracking)
	PTZ Assist	8x 01 04 38 04 pp FF	pp: 2=On, 3=Off, 10=Toggle
	AF Sensitivity	8x 01 04 58 0p FF	p: 1=High, 2=Middle, 3=Low
	AF Frame	8x 01 04 5C pp FF	p: 1=Auto, 2=Full Frame,

Command Set	Command	Command Packet	Comments
			3=Center
	Smart AF	8x 01 7E 01 01 0p FF	p: 2=On, 3=Off
Dig-Effect	Mirror	8x 01 04 61 0p FF	p: 2=On, 3=Off
	Flip	8x 01 04 66 0p FF	p: 2=On, 3=Off
Ethernet	DHCP	8x 01 7C 01 0p FF	p: 2=On, 3=Off
	IP Address	8x 01 7C 02 0p 0q 0r 0s 0t 0u 0v 0x FF	address : pq.rs.tu.vx (HEX), pq = 0~255, rs = 0~255, tu = 0~255, vx = 0~255, e.g. 192.168.100.150 => 81 01 7C 02 0C 00 0A 08 06 04 09 06 FF
	Subnet Mask	8x 01 7C 03 0p 0q 0r 0s 0t 0u 0v 0x FF	address : pq.rs.tu.vx (HEX), pq = 0~255, rs = 0~255, tu = 0~255, vx = 0~255, e.g. 255.255.255.0 => 81 01 7C 03 0F 0F 0F 0F 0F 0F 00 00 FF
	Gateway	8x 01 7C 04 0p 0q 0r 0s 0t 0u 0v 0x FF	address : pq.rs.tu.vx (HEX), pq = 0~255, rs = 0~255, tu = 0~255, vx = 0~255, e.g. 192.168.100.254 => 81 01 7C 04 0C 00 0A 08 06 04 0F 0E FF
	DNS	8x 01 7C 05 0p 0q 0r 0s 0t 0u 0v 0x FF	address : pq.rs.tu.vx (HEX), pq = 0~255, rs = 0~255, tu = 0~255, vx = 0~255, e.g. 8.8.8.8 => 81 01 7C 05 00 08 00 08 00 08 00 08 FF
Exposure	Shutter Reset	8x 01 04 0A 00 FF	Reset Shutter Setting to the default value depending on the frame rate of Output Mode (* Available during Shutter Priority/Manual Mode)
	Shutter Up	8x 01 04 0A 02 FF	Shutter Setting (* Available during Shutter Priority/Manual Mode)
	Shutter Down	8x 01 04 0A 03 FF	Shutter Setting (* Available during Shutter Priority/Manual Mode)
	Iris Reset	8x 01 04 0B 00 FF	Reset Iris Setting to 0C (F2.2) value (* Available during Iris Priority/Manual Mode)



Command Set	Command	Command Packet	Comments
Exposure	Iris Up	8x 01 04 0B 02 FF	Iris Up (* Available during Iris Priority/Manual Mode)
	Iris Down	8x 01 04 0B 03 FF	Iris Down (* Available during Iris Priority/Manual Mode)
	Manual Gain Reset	8x 01 04 0C 00 FF	Reset Gain Setting to 0 (0 dB) value (* Available during AE Manual Mode)
	Manual Gain Up	8x 01 04 0C 02 FF	Gain Setting (* Available during AE Manual Mode)
	Manual Gain Down	8x 01 04 0C 03 FF	Gain Setting (* Available during AE Manual Mode)
	Exposure Comp Reset	8x 01 04 0E 00 FF	Reset Exposure Compensation to 5 value (* Available during ExpComp On )
	Exposure Comp Up	8x 01 04 0E 02 FF	Exposure Compensation Up (* Available during ExpComp On )
	Exposure Comp Down	8x 01 04 0E 03 FF	Exposure Compensation Down (* Available during ExpComp On )
	Spot Light Position	8x 01 04 29 0p 0q 0r 0s FF	pq: X-axis, 00 ~ 06 rs: Y-axis, 00 ~ 04
	Iris Limit (Max)	8x 01 04 2A 0p FF	p: Iris F number , p: 3 ~ C (* Disabled during AE Manual Mode and IrisPri Mode)
	Gain Limit	8x 01 04 2C 0p FF	p: 3 ~ F
	WDR	8x 01 04 2D 0p FF	p: WDR mode, 0 ~ 3
	Back Light	8x 01 04 33 0p FF	Back Light Compensation ON/OFF p: 2=On, 3=Off (* Available during Full Auto Mode)
Exposure	Mode	8x 01 04 39 0p FF	p:

Command Set	Command	Command Packet	Comments
			0=Full Auto, 3=Manual, A=Shutter Priority, B=Iris Priority
	Exposure Comp On/Off	8x 01 04 3E 0p FF	p: 2=On, 3=Off (* Disabled during Manual Mode)
	Shutter Direct	8x 01 04 4A 00 00 0p 0q FF	pq: Shutter Position, 00 ~ 15 (* Available during Shutter Priority/Manual Mode)
	Iris Direct	8x 01 04 4B 00 00 0p 0q FF	pq: Iris Position, 00 ~ 0F (* Available during Iris Priority/Manual Mode)
	Manual Gain Direct	8x 01 04 4C 00 00 0p 0q FF	pq: Gain Position, 00 ~ 0F
	Exposure Comp Direct	8x 01 04 4E 00 00 0p 0q FF	pq: 00 ~ 0A
	Spot Light	8x 01 04 59 0p FF	p: 2=On, 3=Off
Focus	Stop	8x 01 04 08 00 FF	Available during Manual Focus Mode
	Far (Standard Speed)	8x 01 04 08 02 FF	Available during Manual Focus Mode
	Near (Standard Speed)	8x 01 04 08 03 FF	Available during Manual Focus Mode
	Far Step	8x 01 04 08 04 FF	Available during Manual Focus Mode
	Near Step	8x 01 04 08 05 FF	Available during Manual Focus Mode
	Far (Variable Speed)	8x 01 04 08 2p FF	p: Speed 0 (Low) ~ 7 (High) (* Available during Manual Focus Mode)
	Near (Variable Speed)	8x 01 04 08 3p FF	p: Speed 0 (Low) ~ 7 (High) (* Available during Manual Focus Mode)
	One Push Trigger	8x 01 04 18 01 FF	One Push AF Trigger (* Available during Manual Focus Mode)
Focus	Mode	8x 01 04 38 0p FF	p: 2=Auto Focus, 3=Manual Focus
	Direct	8x 01 04 48 0p 0q 0r 0s FF	pqrs: Focus Position , pqrs parameters are in the General Zoom

Command Set	Command	Command Packet	Comments
			Focus Table (* Available during Manual Focus Mode)
Menu	Left	8x 01 06 01 01 01 01 03 FF	OSD Menu left
	Right	8x 01 06 01 01 01 02 03 FF	OSD Menu right
	Up	8x 01 06 01 01 01 03 01 FF	OSD Menu up
	Down	8x 01 06 01 01 01 03 02 FF	OSD Menu down
	On/Off	8x 01 06 06 pp FF	Turn on/off OSD menu screen pp: 2=On, 3=Off, 10=Toggle
	Enter	8x 01 7E 01 02 00 01 FF	OSD Menu Enter
Pan Tilt	Pan Flip	8x 01 04 67 3F 0p FF	p: 2=On, 3=Off
	Tilt Flip	8x 01 04 68 3F 0p FF	p: 2=On, 3=Off
	Stop	8x 01 06 01 00 00 03 03 FF	
	UpLeft	8x 01 06 01 VV WW 01 01 FF	VV: Pan Speed 0x01 (Low) ~ 0x18 (High) WW: Tilt Speed 0x01 (Low) ~ 0x18 (High)
	DownLeft	8x 01 06 01 VV WW 01 02 FF	VV: Pan Speed 0x01 (Low) ~ 0x18 (High) WW: Tilt Speed 0x01 (Low) ~ 0x18 (High)
	Left	8x 01 06 01 VV WW 01 03 FF	VV: Pan Speed 0x01 (Low) ~ 0x18 (High) WW: Tilt Speed 0x01 (Low) ~ 0x18 (High)
	UpRight	8x 01 06 01 VV WW 02 01 FF	VV: Pan Speed 0x01 (Low) ~ 0x18 (High) WW: Tilt Speed 0x01 (Low) ~ 0x18 (High)
	DownRight	8x 01 06 01 VV WW 02 02 FF	VV: Pan Speed 0x01 (Low) ~ 0x18 (High) WW: Tilt Speed 0x01 (Low) ~ 0x18 (High)
Pan Tilt	Right	8x 01 06 01 VV WW 02 03 FF	VV: Pan Speed 0x01 (Low) ~ 0x18 (High) WW: Tilt Speed 0x01 (Low) ~ 0x18 (High)
	Up	8x 01 06 01 VV WW 03 01 FF	VV: Pan Speed 0x01 (Low) ~ 0x18 (High) WW: Tilt Speed 0x01 (Low) ~ 0x18 (High)

Command Set	Command	Command Packet	Comments
	Down	8x 01 06 01 VV WW 03 02 FF	VV: Pan Speed 0x01 (Low) ~ 0x18 (High) WW: Tilt Speed 0x01 (Low) ~ 0x18 (High)
	Absolute Position	8x 01 06 02 VV WW 0Y 0Y 0Y 0Y 0Z 0Z 0Z 0Z FF	YYYY : Pan Position 0x0000 ~ 0x6A40 & 0x95C0 ~ 0xFFFF (Center 0000) ZZZZ : Tilt Position 0x0000 ~ 0x3840 & 0xED40 ~ 0xFFFF (Center 0000)
	Relative Position	8x 01 06 03 VV WW 0Y 0Y 0Y 0Y 0Z 0Z 0Z 0Z FF	YYYY : Pan Position 0x0000 ~ 0x6A40 & 0x95C0 ~ 0xFFFF (Center 0000) ZZZZ : Tilt Position 0x0000 ~ 0x3840 & 0xED40 ~ 0xFFFF (Center 0000)
	Home	8x 01 06 04 FF	Go Home Position
	Reset	8x 01 06 05 FF	Initialize Pan Tilt and go to last position
	Pan Tilt Limit	8x 01 06 07 00 0W 0Y 0Y 0Y 0Y 0Z 0Z 0Z 0Z FF	W: 1=Up & Right YYYY: Pan Limit Position 0x0000~0x6A40 ZZZZ: Tilt Limit Position 0x0000~0x3840 W: 0=Down & Left YYYY: Pan Limit Position 0xFFFF~0x95C0 ZZZZ: Tilt Limit Position 0xFFFF~0xED40
	Limit Clear	8x 01 06 07 01 0W 07 0F 0F 0F 07 0F 0F 0F FF	W: 1=Clear Up & Right, 0=Clear Down & Left
Pan Tilt Zoom	PTZ Motion Sync	8x 01 04 38 05 0p FF	p: 2=On, 3=Off
	PTZ Speed Comp	8x 01 06 1F 01 0p FF	p: 0=Off, 1=On
	Preset Speed	8x 01 06 20 0p FF	p: 0=5 deg/sec, 1=25 deg/sec,

Command Set	Command	Command Packet	Comments
			2=50 deg/sec, 3=80 deg/sec, 4=120 deg/sec, 5=160 deg/sec, 6=200 deg/sec, 7=300 deg/sec
Picture	Sharpness Reset	8x 01 04 02 00 FF	Reset Sharpness Setting to 7 value
	Sharpness Up	8x 01 04 02 02 FF	Sharpness Up
	Sharpness Down	8x 01 04 02 03 FF	Sharpness Down
	Brightness Reset	8x 01 04 0D 00 FF	Reset Brightness Setting to 7 value
	Brightness Up	8x 01 04 0D 02 FF	Brightness Up
	Brightness Down	8x 01 04 0D 03 FF	Brightness Down
	Image Mode	8x 01 04 3F 04 0p FF	p: 0=Default, 1=Custom
	Image Mode Load	8x 01 04 3F 05 0p FF	p: 0=Load Image mode - default to Custom (* Available during Image Mode = Custom mode)
	Sharpness Direct	8x 01 04 42 00 00 0p 0q FF	pq: 00 ~ 0E
	Saturation	8x 01 04 49 00 00 0p 0q FF	pq: 00 ~ 0F (* Available during Image Mode = Custom mode)
Brightness Direct	8x 01 04 4D 00 00 0p 0q FF	pq: 00 ~ 0F (* Available during Image Mode = Custom mode)	
Picture	Hue	8x 01 04 4F 00 00 0p 0q FF	pq: 00 ~ 0F (* Available during Image Mode = Custom mode)
	2D NR	8x 01 04 53 0p FF	p: 0=Off, 1=Level 1, 2=Level 2,

Command Set	Command	Command Packet	Comments
			3=Level 3
	3D NR	8x 01 04 54 0p FF	p: 0=Off, 1=Low, 2=Type, 3=Max
	Gamma	8x 01 04 5B 0p FF	p: 0 ~ 3 (* Available during Image Mode = Custom mode)
	Picture Effect	8x 01 04 63 0p FF	p: 0=Off, 2=Neg, 4=B&W
Power	On/Standby	8x 01 04 00 0p FF	p: 2=On, 3=Standby
	Standby Mode	8x 01 7E 01 0A 03 0p FF	p: 2=Normal Standby (Lens Tilt Down), 3=Ceiling Standby (Lens Tilt Up)
Preset	Reset	8x 01 04 3F 00 pp FF	pp: Memory Number 0x00 ~ 0x7F (* Preset address range : 0 ~ 127)
	Set	8x 01 04 3F 01 pp FF	pp: Memory Number 0x00 ~ 0x7F (* Preset address range : 0 ~ 127)
Preset	Recall	8x 01 04 3F 02 pp FF	pp: Memory Number 0x00 ~ 0x7F (* Preset address range : 0 ~ 127)
	Reset	8x 01 04 3F 10 pp FF	pp: Memory Number 0x00 ~ 0x7F (* Preset address range: 128 ~ 255)
	Set	8x 01 04 3F 11 pp FF	pp: Memory Number 0x00 ~ 0x7F (* Preset address range: 128 ~ 255)

Command Set	Command	Command Packet	Comments
	Recall	8x 01 04 3F 12 pp FF	pp: Memory Number 0x00 ~ 0x7F (* Preset address range: 128 ~ 255)
System	Prompt	8x 01 04 07 00 0p FF	p: 2=On, 3=Off
	Baud Rate	8x 01 04 24 00 00 0p FF	p: 0=9600 bps, 1=38400 bps
	Factory Reset (Soft)	8x 01 04 3F 03 00 FF	Reset camera setting
	Factory Reset (Hard)	8x 01 04 3F 03 01 FF	Reset camera and network setting
	Control Port	8x 01 04 53 45 52 49 41 4C 0p FF	p: 2=RS422, 3=RS232
	Initial Position	8x 01 04 75 6A 0p FF	p: 0=Last MEM, 1=1st Preset
	IR Receive	8x 01 06 08 pp FF	pp: 2=On, 3=Off, 10=Toggle
	Protocol	8x 01 06 1F 07 0p FF	p: 0=VISCA, 1=PELCO D
	Output Mode	8x 01 06 35 0p 0q FF	pq: 02=QFHD 4K(3840 x 2160) - 59.94p
	Output Mode	8x 01 06 35 0p 0q FF	pq: 03=QFHD 4K(3840 x 2160) - 50p
	Output Mode	8x 01 06 35 0p 0q FF	pq: 05=QFHD 4K(3840 x 2160) - 29.97p
	Output Mode	8x 01 06 35 0p 0q FF	pq: 06=QFHD 4K(3840 x 2160) - 25p
	Output Mode	8x 01 06 35 0p 0q FF	pq: 08=FHD 1080P(1920 x 1080) - 59.94p
	Output Mode	8x 01 06 35 0p 0q FF	pq: 09=FHD 1080P(1920 x 1080) - 50p
	System	Output Mode	8x 01 06 35 0p 0q FF
Output Mode		8x 01 06 35 0p 0q FF	pq: 0C=FHD 1080P(1920 x 1080) - 25p
Output Mode		8x 01 06 35 0p 0q FF	pq: 0E=HD 720P(1280 x 720) - 59.94p
Output Mode		8x 01 06 35 0p 0q FF	pq: 0F=HD 720P(1280 x 720) - 50p
Output Mode		8x 01 06 35 0p 0q FF	pq: 11=HD 720P(1280 x 720) - 29.97p
Output Mode		8x 01 06 35 0p 0q FF	pq: 12=HD 720P(1280 x 720) - 25p
Output Mode		8x 01 06 35 0p 0q FF	pq: 15=FHD 1080i(1920 x 1080) - 59.94i
	Motionless Preset	8x 01 07 01 0p FF	p: 2=On, 3=Off

Command Set	Command	Command Packet	Comments
	RTMP On/Off	8x 01 7E 7E 0p FF	p: 0=Off, 1=On
Tally	Lamp	8x 01 7E 01 0A 00 0p FF	p: 2=Enable, 3=Disable
	Mode	8x 01 7E 01 0A 01 0p FF	p: 0=Red-Off / Green-Off, 4=Red-On (Low) / Green-Off, 5=Red-On (High) / Green-Off, 6=Red-Off / Green-On, 7=Red-On (High) / Green-On, (* Tally Lamp must be Enabled for non-zero value)
	CMMD Mode	8x 01 7E 01 0A 04 0p FF	p: 2=Link, 3=Normal
White Balance	Manual Red Reset	8x 01 04 03 00 FF	Reset R Gain Setting to 40 (64) value (* Available during WB Manual mode)
	Manual Red Up	8x 01 04 03 02 FF	R Gain Up (* Available during WB Manual mode)
	Manual Red Down	8x 01 04 03 03 FF	R Gain Down (* Available during WB Manual mode)
	Manual Blue Reset	8x 01 04 04 00 FF	Reset B Gain Setting to 40 (64) value (* Available during WB Manual mode)
White Balance	Manual Blue Up	8x 01 04 04 02 FF	B Gain Up (* Available during WB Manual mode)
	Manual Blue Down	8x 01 04 04 03 FF	B Gain Down (* Available during WB Manual mode)
	One Push Trigger	8x 01 04 10 05 FF	One Push WB Trigger (* Available during One Push WB Mode)
	Mode	8x 01 04 35 0p FF	p: 0=Auto,



Command Set	Command	Command Packet	Comments
			1=Indoor, 2=Outdoor, 3=One Push WB, 4=ATW, 5=Manual, 6=3000K, 7=4300K, 8=5000K, 9=6500K, A=8000K, C=Sodium Lamp
	Manual Red Direct	8x 01 04 43 00 00 0p 0q FF	pq: 00 ~ 80 (0 ~ 128)
	Manual Blue Direct	8x 01 04 44 00 00 0p 0q FF	pq: 00 ~ 80 (0 ~ 128)
Zoom	Stop	8x 01 04 07 00 FF	
	Tele (Standard Speed)	8x 01 04 07 02 FF	
	Wide (Standard Speed)	8x 01 04 07 03 FF	
	Tele Step	8x 01 04 07 04 FF	
Zoom	Wide Step	8x 01 04 07 05 FF	
	Tele (Variable Speed)	8x 01 04 07 2p FF	p=0 (Low) ~ 7 (High)
	Wide (Variable Speed)	8x 01 04 07 3p FF	p=0 (Low) ~ 7 (High)
	Digital Zoom Limit	8x 01 04 26 0p FF	p: 0 (x1) ~ B (x12)
	Direct (Variable Speed)	8x 01 04 47 0p 0q 0r 0s 0t FF	pqr: Zoom Position, Min. 0000h Max. 4000h (In D-Zoom Limit = x1) Max. 7AC0h (In D-Zoom Limit = x2 ~ 12x) t: Zoom Speed, 0 (Low) ~ 7 (High)

Command Set	Command	Command Packet	Comments
	Direct (Standard Speed)	8x 01 04 47 0p 0q 0r 0s FF	pqrs: Zoom Position, Min. 0000h Max. 4000h (In Dzoom Limit = x1) Max. 7AC0h (In D-Zoom Limit = x2 ~ 12x)
Zoom Focus	Direct (Variable Speed)	8x 01 04 47 0p 0q 0r 0s 0t 0u 0v 0w 0x FF	pqrs: Zoom Position, 0x0000 ~ 0x4000 tuvw: Focus Position, 0x0000 ~ FocusMaxValue x: Speed, 0 ~ 7 (* Available during Manual Focus Mode)
	Direct (Standard Speed)	8x 01 04 47 0p 0q 0r 0s 0t 0u 0v 0w FF	pqrs: Zoom Position, 0x0000 ~ 0x4000 tuvw: Focus Position, 0x0000 ~ FocusMaxValue (* Available during Manual Focus Mode)

## 13 RS232 Inquiry Command List

Command Set	Inquiry Command	Command Packet	Inquiry Packet	Comments
Audio	Audio Enable Inq	8x 09 04 68 FF	y0 50 0p FF	p: 2=On, 3=Off
	Delay Time Inq	8x 09 04 6A FF	y0 50 0p 0q 0r FF	pqr : delay time, range: 001 ~ 1F4 (1 ~ 500)
	Audio In Inq	8x 09 04 6B FF	y0 50 0p FF	p: 2=Line In, 3=Mic In
	Encode Sample Rate Inq	8x 09 04 6D FF	y0 50 0p FF	p: 0=48 KHz (AAC), 1=44.1 KHz (AAC), 2=16 KHz (AAC), 3=16 KHz (G.711), 4=8 KHz (G.711)
	Audio Volume Inq	8x 09 04 6E FF	y0 50 0p FF	p: 0 ~ A (0 ~ 10)
	Delay Enable Inq	8x 09 04 6F FF	y0 50 0p FF	p: 2=On, 3=Off
Auto Focus	Zoom Tracking Inq	8x 09 04 38 03 FF	y0 50 0p FF	p: 2=Off (Curve Tracking), 3=On (Zoom Tracking)
	PTZ Assist Inq	8x 09 04 38 04 FF	y0 50 0p FF	p: 2=On, 3=Off
	AF Sensitivity Inq	8x 09 04 58 FF	y0 50 0p FF	p: 1=High, 2=Middle, 3=Low
	AF Frame Inq	8x 09 04 5C FF	y0 50 0p FF	p: 1=Auto, 2=Full Frame, 3=Center
	Smart AF Inq	8x 09 7E 01 01 FF	y0 50 0p FF	p: 2=On, 3=Off
Dig-Effect	Mirror Inq	8x 09 04 61 FF	y0 50 0p FF	p: 2=On, 3=Off
Dig-Effect	Flip Inq	8x 09 04 66 FF	y0 50 0p FF	p: 2=On, 3=Off

Command Set	Inquiry Command	Command Packet	Inquiry Packet	Comments
Ethernet	MAC Address Inq	8x 09 04 78 FF	y0 50 0a 0b 0c 0d 0e 0f 0g 0h 0i 0j 0k 0l FF	MAC Address = ab: cd: ef: gh: ij: kl
	DHCP Inq	8x 09 7C 01 FF	y0 50 0p FF	p: 2=On, 3=Off
	IP Address Inq	8x 09 7C 02 FF	y0 50 0p 0q 0r 0s 0t 0u 0v 0x FF	address : pq.rs.tu.vx (HEX)
	Subnet Mask Inq	8x 09 7C 03 FF	y0 50 0p 0q 0r 0s 0t 0u 0v 0x FF	address : pq.rs.tu.vx (HEX)
	Gateway Inq	8x 09 7C 04 FF	y0 50 0p 0q 0r 0s 0t 0u 0v 0x FF	address : pq.rs.tu.vx (HEX)
	DNS Inq	8x 09 7C 05 FF	y0 50 0p 0q 0r 0s 0t 0u 0v 0x FF	address : pq.rs.tu.vx (HEX)
Exposure	Spot Light Position Inq	8x 09 04 29 FF	y0 50 0p 0q 0r 0s FF	pq: X-axis, 00 ~ 06 rs: Y-axis, 00 ~ 04
	Iris Limit Inq (Max)	8x 09 04 2A FF	y0 50 0p FF	p: Iris Limit, 3 ~ C (* Disabled during AE Manual Mode and IrisPri Mode)
	Gain Limit Inq	8x 09 04 2C FF	y0 50 0p FF	p: 3 ~ F
	WDR Inq	8x 09 04 2D FF	y0 50 0p FF	p: WDR mode, 00 ~ 03
	Back Light Inq	8x 09 04 33 FF	y0 50 0p FF	p: 2=On, 3=Off
	Mode Inq	8x 09 04 39 FF	y0 50 0p FF	p: 0=Full Auto, 3=Manual, A=Shutter Priority, B=Iris Priority
	Exposure Comp Inq	8x 09 04 3E FF	y0 50 0p FF	p: 2=On, 3=Off
	Shutter Inq	8x 09 04 4A FF	y0 50 00 00 0p 0q FF	pq: Shutter Position, 00 ~ 15
	Iris Inq	8x 09 04 4B FF	y0 50 00 00 0p 0q FF	pq: Iris Position, 00 ~ 0F
	Manual Gain Inq	8x 09 04 4C FF	y0 50 00 00 0p 0q FF	pq: Gain Position, 00 ~ 0F
Exposure Comp Level Inq	8x 09 04 4E FF	y0 50 00 00 0p 0q FF	pq: 00 ~ 0A	
Exposure	Spot Light Inq	8x 09 04 59 FF	y0 50 0p FF	p: 2=On, 3=Off

Command Set	Inquiry Command	Command Packet	Inquiry Packet	Comments
Focus	Mode Inq	8x 09 04 38 FF	y0 50 0p FF	p: 2=Auto Focus, 3=Manual Focus
	Position Inq	8x 09 04 48 FF	y0 50 0p 0q 0r 0s FF	pqrs: Focus Position, parameters are in the General Zoom Focuss Table near end to far end
Menu	Menu Mode Inq	8x 09 06 06 FF	y0 50 0p FF	p: 2=On, 3=Off
Pan Tilt	Pan Flip Inq	8x 09 04 67 3F FF	y0 50 0p FF	p: 2=On, 3=Off
	Tilt Flip Inq	8x 09 04 68 3F FF	y0 50 0p FF	p: 2=On, 3=Off
	Position Inq	8x 09 06 12 FF	y0 50 0w 0w 0w 0w 0z 0z 0z 0z FF	www: Pan Position 0000 ~ 6A40 & 95C0 ~ FFFF (center 0000) zzzz: Tilt Position 0000 ~ 3840 & ED40 ~ FFFF (center 0000)
Pan Tilt Zoom	PTZ Motion Sync Inq	8x 09 04 38 05 FF	y0 50 0p FF	p: 2=On, 3=Off
	PTZ Speed Comp Inq	8x 09 06 1F 01 FF	y0 50 0p FF	p: 0=Off, 1=On
Picture	Image Mode Inq	8x 09 04 3F 04 FF	y0 50 0p FF	p: 0=Default, 1=Custom
	Sharpness Inq	8x 09 04 42 FF	y0 50 00 00 0p 0q FF	pq: 00 ~ 0E
	Saturation Inq	8x 09 04 49 FF	y0 50 00 00 0p 0q FF	pq: 00 ~ 0F
	Brightness Inq	8x 09 04 4D FF	y0 50 00 00 0p 0q FF	pq: 00 ~ 0F
	Hue Inq	8x 09 04 4F FF	y0 50 00 00 0p 0q FF	pq: 00 ~ 0F
	2D NR Inq	8x 09 04 53 FF	y0 50 0p FF	p: 0=Off, 1=Level 1, 2=Level 2, 3=Level 3
	3D NR Inq	8x 09 04 54 FF	y0 50 0p FF	p: 0=Off, 1=Low, 2=Type,

Command Set	Inquiry Command	Command Packet	Inquiry Packet	Comments
				3=Max
Picture	Gamma Inq	8x 09 04 5B FF	y0 50 0p FF	Gamma p: 0 ~ 3
	Picture Effect Inq	8x 09 04 63 FF	y0 50 0p FF	p: 0=Off, 2=Neg, 4=B&W
Power	Power Mode Inq	8x 09 04 00 FF	y0 50 0p FF	p: 2=On, 3=Standby
System	Prompt Inq	8x 09 04 07 00 FF	y0 50 0p FF	p: 2=On, 3=Off
	Baud Rate Inq	8x 09 04 24 00 FF	y0 50 00 0p FF	p: 0=9600 bps, 1=38400 bps
	Initial Position Inq	8x 09 04 75 6A FF	y0 50 0p FF	p: 0=Last MEM, 1=1st Preset
	IR Receive Inq	8x 09 06 08 FF	y0 50 0p FF	p: 2=On, 3=Off
	Output Mode Inq	8x 09 06 23 FF	y0 50 0p 0q FF	pq: 02=QFHD 4K(3840 x 2160) - 59.94p
	Output Mode Inq	8x 09 06 23 FF	y0 50 0p 0q FF	pq: 03=QFHD 4K(3840 x 2160) - 50p
	Output Mode Inq	8x 09 06 23 FF	y0 50 0p 0q FF	pq: 05=QFHD 4K(3840 x 2160) - 29.97p
	Output Mode Inq	8x 09 06 23 FF	y0 50 0p 0q FF	pq: 06=QFHD 4K(3840 x 2160) - 25p
	Output Mode Inq	8x 09 06 23 FF	y0 50 0p 0q FF	pq: 08=FHD 1080P(1920 x 1080) - 59.94p
	Output Mode Inq	8x 09 06 23 FF	y0 50 0p 0q FF	pq: 09=FHD 1080P(1920 x 1080) - 50p
	Output Mode Inq	8x 09 06 23 FF	y0 50 0p 0q FF	pq: 0B=FHD 1080P(1920 x 1080) - 29.97p
	Output Mode Inq	8x 09 06 23 FF	y0 50 0p 0q FF	pq: 0C=FHD 1080P(1920 x 1080) - 25p
	Output Mode Inq	8x 09 06 23 FF	y0 50 0p 0q FF	pq: 0E=HD 720P(1280 x 720) - 59.94p
	Output Mode Inq	8x 09 06 23 FF	y0 50 0p 0q FF	pq: 0F=HD 720P(1280 x 720) - 50p
	Output Mode Inq	8x 09 06 23 FF	y0 50 0p 0q FF	pq: 11=HD 720P(1280 x 720) - 29.97p
	Output Mode Inq	8x 09 06 23 FF	y0 50 0p 0q FF	pq: 12=HD 720P(1280 x 720) - 25p
Output Mode Inq	8x 09 06 23 FF	y0 50 0p 0q FF	pq: 15=FHD 1080i(1920 x 1080) - 59.94i	
System	Output Mode Inq	8x 09 06 23 FF	y0 50 0p 0q FF	pq: 16=FHD 1080i(1920 x 1080) - 50i
	Motionless Preset Inq	8x 09 07 01 FF	y0 50 0p FF	p: 2=On, 3=Off

Command Set	Inquiry Command	Command Packet	Inquiry Packet	Comments
Tally	Lamp Inq	8x 09 7E 01 0A 00 FF	y0 50 0p FF	p: 2=Enable, 3=Disable
	Mode Inq	8x 09 7E 01 0A 01 FF	y0 50 0p FF	p: 0=Red-Off / Green-Off, 4=Red-On (Low) / Green-Off, 5=Red-On (High) / Green-Off, 6=Red-Off / Green-On, 7=Red-On (High) / Green-On
White Balance	Mode Inq	8x 09 04 35 FF	y0 50 0p FF	p: 0=Auto, 1=Indoor, 2=Outdoor, 3=One Push WB, 4=ATW, 5=Manual, 6=3000K, 7=4300K, 8=5000K, 9=6500K, A=8000K, C=Sodium Lamp
	Manual Red Inq	8x 09 04 43 FF	y0 50 00 00 0p 0q FF	pq: 00 ~ 80 (0 ~ 128)
	Manual Blue Inq	8x 09 04 44 FF	y0 50 00 00 0p 0q FF	pq: 00 ~ 80 (0 ~ 128)
Zoom	Digital Zoom Limit Inq	8x 09 04 26 FF	y0 50 pq FF	p: 0 (x1) ~ B (x12)
	Position Inq	8x 09 04 47 FF	y0 50 0p 0q 0r 0s FF	pqrs: Zoom Position, Min. 0000h Max. 4000h (In Dzoom Limit = x1) Max. 7AC0h (In D-Zoom Limit = x2 ~ 12x)

## Camera Block Inquiry Command List 14.1 CAM Lens Control Blocking

Byte	Bit	Comments
Byte0	0	Source Address
	1	
	2	
	3	
	4	Destination Address
	5	
	6	
7		
Byte1	0	0
	1	0
	2	0
	3	0
	4	1
	5	0
	6	1
	7	0
Byte2	0	Zoom Position (HH)
	1	
	2	
	3	
	4	0
	5	0
	6	0
	7	0

Byte	Bit	Comments
Byte3	0	Zoom Position (HL)
	1	
	2	
	3	
	4	0
	5	0
	6	0
	7	0
Byte4	0	Zoom Position (LH)
	1	
	2	
	3	
	4	0
	5	0
	6	0
	7	0
Byte5	0	Zoom Position (LL)
	1	
	2	
	3	
	4	0
	5	0
	6	0
	7	0

Byte	Bit	Comments
Byte6	0	0
	1	0
	2	0
	3	0
	4	0
	5	0
	6	0
	7	0
Byte7	0	0
	1	0
	2	0
	3	0
	4	0
	5	0
	6	0
	7	0
Byte8	0	Focus Position (HH)
	1	
	2	
	3	
	4	0
	5	0
	6	0
	7	0



Byte	Bit	Comments
Byte9	0	Focus Position (HL)
	1	
	2	
	3	
	4	0
	5	0
	6	0
	7	0
Byte10	0	Focus Position (LH)
	1	
	2	
	3	
	4	0
	5	0
	6	0
	7	0
Byte11	0	Focus Position (LL)
	1	
	2	
	3	
	4	0
	5	0
	6	0

Byte	Bit	Comments
	7	0
Byte12	0	Focus Mode 0:Manual 1:Auto
	1	Digital Zoom 0:Off 1:On
	2	0
	3	0
	4	0
	5	0
	6	0
	7	0
Byte13	0	0
	1	0
	2	0
	3	0
	4	0
	5	0
	6	0
	7	0
Byte14	0	0
	1	0
	2	0
	3	0

Byte	Bit	Comments
	4	0
	5	0
	6	0
	7	0
Byte15	0	1
	1	1
	2	1
	3	1
	4	1
	5	1
	6	1
	7	1

## 14.2 CAM\_Camera\_Control\_BlockInq

Byte	Bit	Comments
Byte0	0	Source Address
	1	
	2	
	3	
	4	Destination Address
	5	
	6	
	7	
Byte1	0	0
	1	0
	2	0
	3	0
	4	1
	5	0
	6	1
	7	0
Byte2	0	R Gain (H)
	1	
	2	
	3	
	4	0
	5	0
	6	0
	7	0

Byte	Bit	Comments
Byte3	0	R Gain (L)
	1	
	2	
	3	
	4	0
	5	0
	6	0
	7	0
Byte4	0	B Gain (H)
	1	
	2	
	3	
	4	0
	5	0
	6	0
	7	0
Byte5	0	B Gain (L)
	1	
	2	
	3	
	4	0
	5	0
	6	0
	7	0

Byte	Bit	Comments
Byte6	0	WB Mode
	1	
	2	
	3	
	4	0
	5	0
	6	0
	7	0
Byte7	0	Aperture Gain
	1	
	2	
	3	
	4	0
	5	0
	6	0
	7	0
Byte8	0	Exposure Mode
	1	
	2	
	3	
	4	0
	5	0
	6	0
	7	0

Byte	Bit	Comments
Byte9	0	Slow Shutter 0:Off 1:On
	1	Exposure Comp. 0:Off 1:On
	2	Backlight 0:Off 1:On
	3	Spot AE 0:Off 1:On
	4	WDR 0:Off 1:On
	5	0
	6	0
	7	0
Byte10	0	Shutter Position
	1	
	2	
	3	
	4	
	5	
	6	0
	7	0
Byte11	0	Iris Position
	1	
	2	

Byte	Bit	Comments	
	3		
	4		
	5		0
	6		0
	7		0
Byte12	0	Gain Position	
	1		
	2		
	3		
	4		
	5		0
	6		0
	7		0
Byte13	0	0	
	1	0	
	2	0	
	3	0	
	4	0	
	5	0	
	6	0	
	7	0	
Byte14	0	Exposure Comp. Position	
	1		
	2		

Byte	Bit	Comments	
	3		
	4		0
	5		0
	6		0
	7		0
Byte15	0	1	
	1	1	
	2	1	
	3	1	
	4	1	
	5	1	
	6	1	
	7	1	

## 14.3 CAM\_Other\_Blocking

Byte	Bit	Comments
Byte0	0	Source Address
	1	
	2	
	3	
	4	Destination Address
	5	
	6	
	7	
Byte1	0	0
	1	0
	2	0
	3	0
	4	1
	5	0
	6	1
	7	0
Byte2	0	Power 0:Off 1:On
	1	0
	2	Auto ICR 0:Off 1:On
	3	0
	4	1
	5	0
	6	1

Byte	Bit	Comments
	7	0
Byte3	0	0
	1	0
	2	LR Reverse 0:Off 1:On
	3	0
	4	ICR 0:Off 1:On
	5	0
	6	0
	7	0
Byte4	0	0
	1	0
	2	0
	3	0
	4	0
	5	0
	6	0
	7	0
Byte5	0	Picture Effect Mode
	1	
	2	
	3	
	4	0
	5	0

Byte	Bit	Comments
	6	0
	7	0
Byte6	0	0
	1	0
	2	0
	3	0
	4	0
	5	0
	6	0
	7	0
Byte7	0	0
	1	0
	2	0
	3	0
	4	0
	5	0
	6	0
	7	0
Byte8	0	0
	1	0
	2	0
	3	0
	4	0
	5	0
	6	0
	7	0

Byte	Bit	Comments
Byte9	0	0
	1	0
	2	0
	3	0
	4	0
	5	0
	6	0
	7	0
Byte10	0	0
	1	0
	2	0
	3	0
	4	0
	5	0
	6	0
	7	0
Byte11	0	0
	1	0
	2	0
	3	0
	4	0
	5	0
	6	0
	7	0

Byte	Bit	Comments	
	7	0	
Byte12	0	System 1:1/50, 1/25 0:1/59.94, 1/29.97	
	1	0	
	2	ICR 1:Provided 0:Not provided	
	3	0	
	4	Memory 1:Provided 0:Not provided	
	5	0	
	6	0	
	7	0	
	Byte13	0	0
		1	0
2		0	
3		0	
4		0	
5		0	
6		0	
7		0	
Byte14	0	0	

Byte	Bit	Comments
	1	0
	2	0
	3	0
	4	0
	5	0
	6	0
	7	0
Byte15	0	1
	1	1
	2	1
	3	1
	4	1
	5	1
	6	1
	7	1

## 14.4 CAM\_Extended\_1\_BlockInq

Byte	Bit	Comments
Byte0	0	Source Address
	1	
	2	
	3	
	4	Destination Address
	5	
	6	
7		
Byte1	0	0
	1	0
	2	0
	3	0
	4	1
	5	0
	6	1
	7	0
Byte2	0	0
	1	0
	2	0
	3	0
	4	0
	5	0
	6	0
	7	0

Byte	Bit	Comments
Byte3	0	0
	1	0
	2	0
	3	0
	4	0
	5	0
	6	0
	7	0
Byte4	0	0
	1	0
	2	0
	3	0
	4	0
	5	0
	6	0
	7	0
Byte5	0	0
	1	0
	2	0
	3	0
	4	0
	5	0
	6	0
	7	0

Byte	Bit	Comments
Byte6	0	0
	1	0
	2	0
	3	0
	4	0
	5	0
	6	0
	7	0
Byte7	0	0
	1	0
	2	0
	3	0
	4	0
	5	0
	6	0
	7	0
Byte8	0	Spot AE Position (X)
	1	
	2	
	3	
	4	0
	5	0
	6	0
	7	0

Byte	Bit	Comments
Byte9	0	Spot AE Position (Y)
	1	
	2	
	3	
	4	0
	5	0
	6	0
	7	0
Byte10	0	Flip 0:Off 1:On
	1	0
	2	0
	3	0
	4	0
	5	0
	6	0
	7	0
Byte11	0	Flip 1:Provided 0:Not provided
	1	0
	2	0
	3	0
	4	Color Gain

Byte	Bit	Comments
	5	
	6	
	7	
Byte12	0	0
	1	0
	2	0
	3	0
	4	0
	5	0
	6	0
	7	0
Byte13	0	0
	1	0
	2	0
	3	0
	4	Gamma
	5	
	6	
	7	0
Byte14	0	Gain Limit
	1	
	2	
	3	
	4	

Byte	Bit	Comments
	5	0
	6	0
	7	0
Byte15	0	1
	1	1
	2	1
	3	1
	4	1
	5	1
	6	1
	7	1

## 14.5 CAM\_Extended\_2\_BlockInq

Byte	Bit	Comments
Byte0	0	Source Address
	1	
	2	
	3	
	4	Destination Address
	5	
	6	
7		
Byte1	0	0
	1	0
	2	0
	3	0
	4	1
	5	0
	6	1
	7	0
Byte2	0	WDR Index
	1	
	2	
	3	
	4	0
	5	0
	6	0
	7	0

Byte	Bit	Comments
Byte3	0	0
	1	0
	2	0
	3	0
	4	0
	5	0
	6	0
	7	0
Byte4	0	0
	1	0
	2	0
	3	0
	4	0
	5	0
	6	0
	7	0
Byte5	0	0
	1	0
	2	0
	3	0
	4	0
	5	0
	6	0
	7	0

Byte	Bit	Comments
Byte6	0	0
	1	0
	2	0
	3	0
	4	0
	5	0
	6	0
	7	0
Byte7	0	0
	1	0
	2	0
	3	0
	4	0
	5	0
	6	0
	7	0
Byte8	0	0
	1	0
	2	0
	3	0
	4	0
	5	0
	6	0
	7	0



Byte	Bit	Comments
Byte9	0	0
	1	0
	2	0
	3	0
	4	0
	5	0
	6	0
	7	0
Byte10	0	0
	1	0
	2	0
	3	0
	4	0
	5	0
	6	0
	7	0
Byte11	0	0
	1	0
	2	0
	3	0
	4	0
	5	0
	6	0
	7	0

Byte	Bit	Comments
Byte12	0	0
	1	0
	2	0
	3	0
	4	0
	5	0
	6	0
	7	0
Byte13	0	0
	1	0
	2	0
	3	0
	4	0
	5	0
	6	0
	7	0
Byte14	0	0
	1	0
	2	0
	3	0
	4	0
	5	0
	6	0
	7	0

Byte	Bit	Comments
Byte15	0	1
	1	1
	2	1
	3	1
	4	1
	5	1
	6	1
	7	1

## 14.6 CAM\_Extended\_3\_BlockInq

Byte	Bit	Comments
Byte0	0	Source Address
	1	
	2	
	3	
	4	Destination Address
	5	
	6	
7		
Byte1	0	0
	1	0
	2	0
	3	0
	4	1
	5	0
	6	1
	7	0
Byte2	0	Color Hue
	1	
	2	
	3	
	4	0
	5	0
	6	0
	7	0

Byte	Bit	Comments
Byte3	0	0
	1	0
	2	0
	3	0
	4	0
	5	0
	6	0
	7	0
Byte4	0	0
	1	0
	2	0
	3	0
	4	0
	5	0
	6	0
	7	0
Byte5	0	0
	1	0
	2	0
	3	0
	4	0
	5	0
	6	0
	7	0

Byte	Bit	Comments
Byte6	0	0
	1	0
	2	0
	3	0
	4	0
	5	0
	6	0
	7	0
Byte7	0	0
	1	0
	2	0
	3	0
	4	0
	5	0
	6	0
	7	0
Byte8	0	0
	1	0
	2	0
	3	0
	4	0
	5	0
	6	0
	7	0



Byte	Bit	Comments
Byte9	0	0
	1	0
	2	0
	3	0
	4	0
	5	0
	6	0
	7	0
Byte10	0	0
	1	0
	2	0
	3	0
	4	0
	5	0
	6	0
	7	0
Byte11	0	0
	1	0
	2	0
	3	0
	4	0
	5	0
	6	0
	7	0

Byte	Bit	Comments
Byte12	0	0
	1	0
	2	0
	3	0
	4	0
	5	0
	6	0
	7	0
Byte13	0	0
	1	0
	2	0
	3	0
	4	0
	5	0
	6	0
	7	0
Byte14	0	0
	1	0
	2	0
	3	0
	4	0
	5	0
	6	0
	7	0

Byte	Bit	Comments
Byte15	0	1
	1	1
	2	1
	3	1
	4	1
	5	1
	6	1
	7	1

## RS232 over IP

### a. Overview of RS232 over IP

RS232 over IP allows you to control this unit from the controller with the IP communication function via the LAN by using RS232.

You can connect up to 5 controllers simultaneously on one LAN segment.

The communication specifications of RS232 over IP are as follows:

### b. Interface

RJ-45 10Base-T/100Base-TX (automatic discrimination)

### c. Internet protocol

IPv4

### d. Transport protocol

UDP

### e. IP address

Set by the IP card setting command

### f. Port address

52381

### g. Delivery confirmation/Retransmission control

Depends on the application

### h. Coverage

Limited dedicated network in the same segment without going through a bridge connection.

In this section, the device outputting commands, for example, a computer, is called the controller, and this unit and the devices connected to the same LAN are called the peripheral device. In the connection using RS-232/RS-422, the controllers and peripheral devices are connected to a one-direction ring. On the IP communication connection, the controllers and peripheral devices are connected by star type through a LAN.

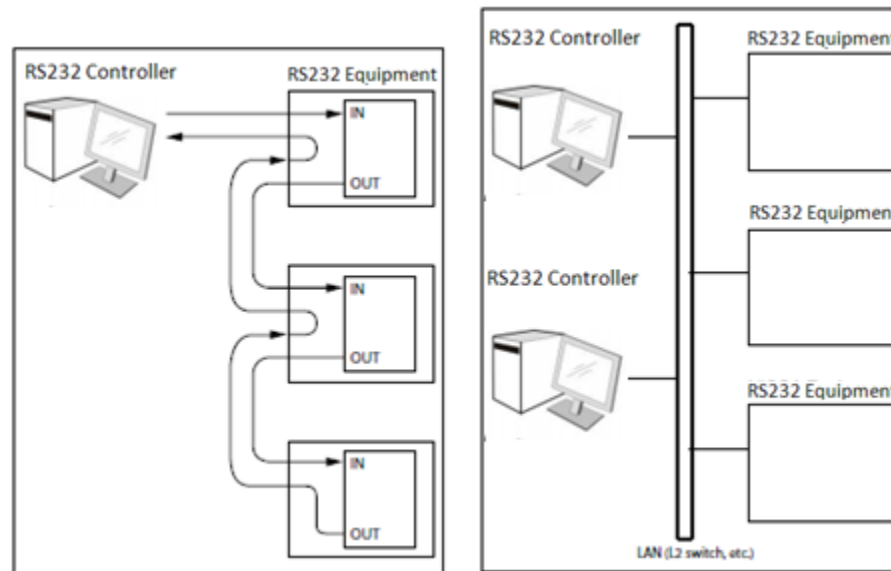

**RS232/RS422 connection**

**IP communication connection**

While the IP communication connection, the address of each device cannot be set in the RS232 message as it is because the controllers and peripheral devices that are connected simultaneously are increased. In this case, addresses of the controllers and peripheral devices that are set in the RS232 message are locked to 0 (for the controller) or 1 (for the peripheral device).

### **i. Packet Structure**

The basic unit of VISCA communication is called a packet [Pic.1]. The first byte of the packet is called the header and comprises the sender's and receiver's addresses. For example, the header of the packet sent to the SRG assigned address 1 from the controller (address 0) is 81h in hexadecimal. The packet sent to the SRG assigned address 2 is 82h. In the command list, as the header is 8X, input the address of the SRG to X. The header of the reply packet from the SRG assigned address 1 is 90h. The packet from the SRG assigned address 2 is A0h.

Some of the setting commands for SRG can be sent to all devices at one time (broadcast)\*. In the case of broadcast, the header should be 88h in hexadecimal.

When the terminator is FFh, it signifies the end of the packet.

\*The broadcast function is not available for VISCA over IP.

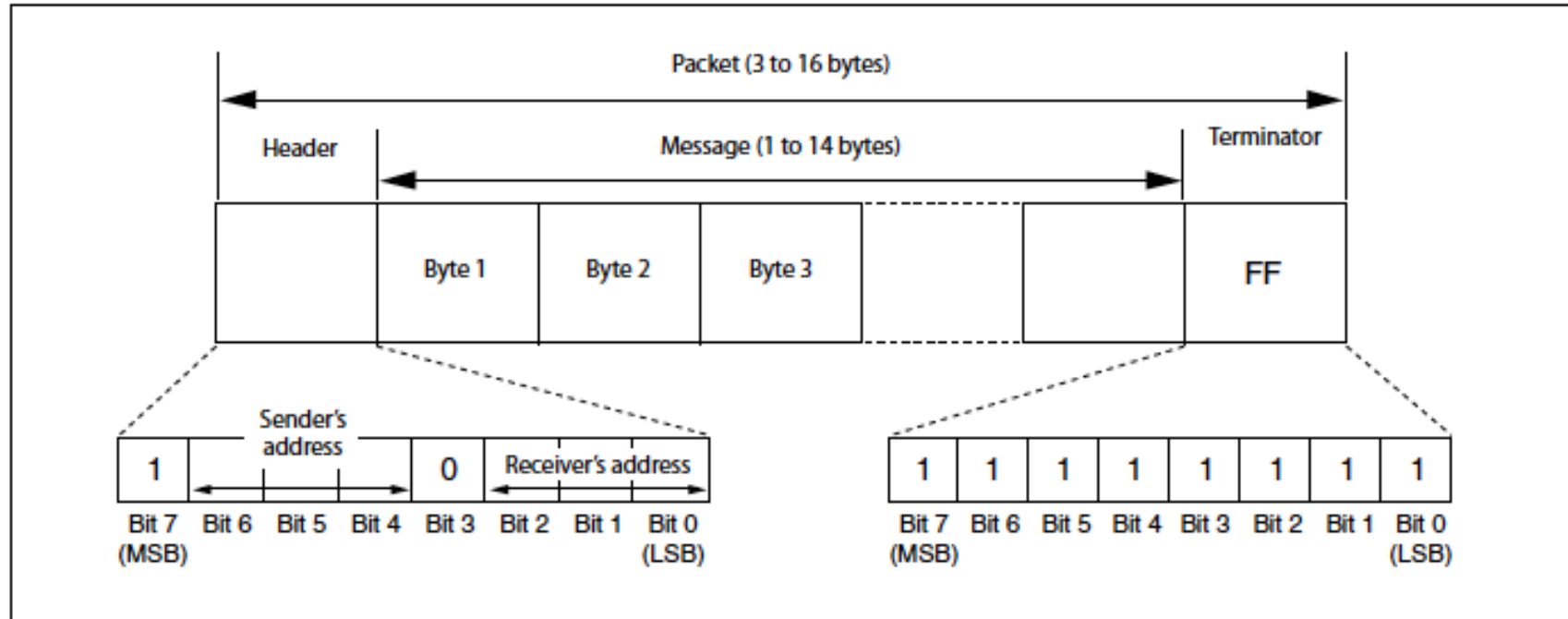

Pic. 1 Packet structure

Note:

Pic. 1 shows the packet structure, while Pic.2 shows the actual waveform. Data flow will take place with the LSB first.

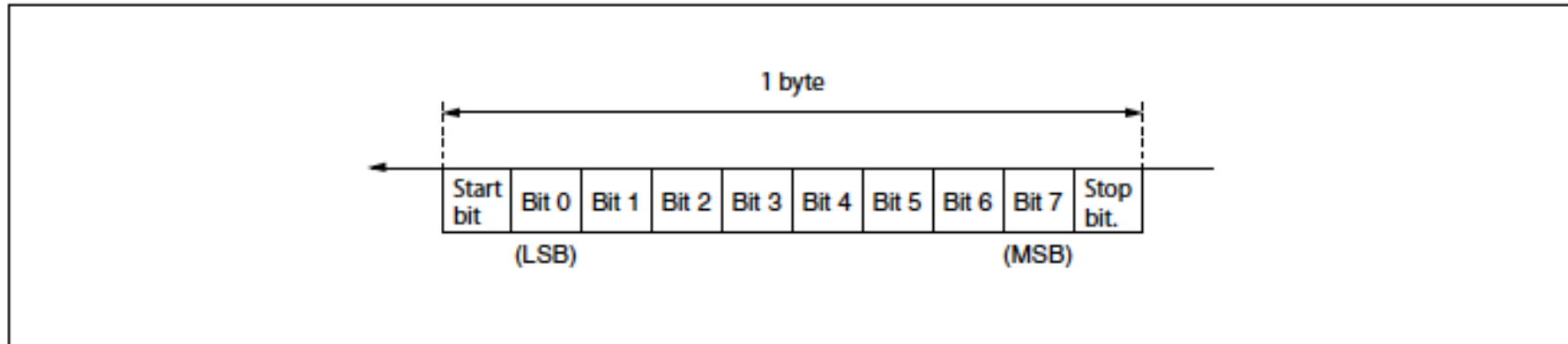

Pic. 2 Actual waveform for 1 byte

## 2 Communication method of VISCA over IP

### a. Communication method

VISCA over IP can process the VISCA communication between the controllers and peripheral devices using the messages that can be identified on the LAN, and sends/receives them. Because of this, VISCA over IP is not concerned about the contents of the communication between the controllers and peripheral devices. However, the VISCA communication sequence is different, depending on the types, as follows.

### b. VISCA command

This is a command from the controller to the peripheral device. When the peripheral device receives this command, Acknowledge is returned. After completing command processing, a completion notice is returned. This command uses the socket of VISCA. The order of completion notices may be changed if the multiple commands are sent to the same peripheral device.

### c. VISCA inquiry

This is an inquiry from the controller to the peripheral device. When the peripheral device receives this type of command, the reply for the inquiry is returned. This command does not use the socket of VISCA. The order of the replies is not changed if a multiple commands are sent.



**d. VISCA reply**

This is an Acknowledge, completion notice, reply, or error reply from the peripheral device to the controller. The classification for sending messages from the peripheral device to the controller is common.

**e. VISCA device setting command**

This is the device setting command from the controller to the peripheral device. When the peripheral device receives this classifications command, the peripheral device performs the function depend on the command.

**f. Address**

Sets the address of the peripheral device, and does not return a reply to the controller. While using VISCA over IP, the address command is not sent from the controller because a Network Change command from the peripheral device that triggers sending command is not issued.

**g. IF\_Clear**

Sends the reply message to the controller after clearing, without using VISCA socket.

**h. CAM\_VerslonInq**

Sends the reply message to the controller, without using VISCA socket.

**i. Format**

These are the specifications of the message header (8 bytes) and payload (1 to 16 bytes).

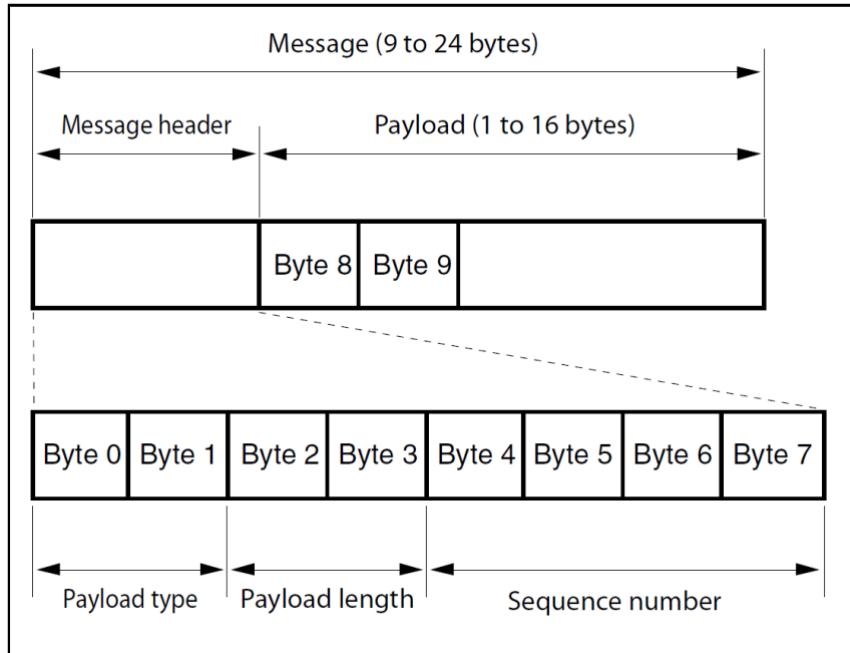

Note: The actual LAN out method is big-endian, LSB first.  
 Pic.3 Message structure of the VISCA over IP

Example:

Command	Payload type		Payload length		Sequence number				Payload (1~16Byte)										
	Byte 0	Byte 1	Byte 2	Byte 3	Byte 4	Byte 5	Byte 6	Byte 7	Byte 1	Byte 2	Byte 3	Byte 4	Byte 5	Byte 6	Byte 7	Byte 8	Byte 9	...	Byte 16
CAM_Power On	01	00	00	06	00	00	00	01	81	01	04	00	02	FF					
Pan-tiltDrive Up	01	00	00	09	00	00	00	02	81	01	06	01	0C	0C	03	01	FF		
Pan-tiltDrive Down	01	00	00	09	00	00	00	03	81	01	06	01	0C	0C	03	02	FF		
CAM_FocusModeInq	01	10	00	5	00	00	00	04	81	9	4	38	FF						

### j. Payload type

Stores the value (Byte 0 and Byte 1) of the following table on the payload division.

Name	Value (Byte 0)	Value (Byte 1)	Description
VISCA command	01h	00h	Stores the VISCA command.
VISCA inquiry	01h	10h	Stores the VISCA inquiry.
VISCA reply	01h	11h	Stores the reply for the VISCA command and VISCA inquiry, or VISCA device setting command.
VISCA device setting command	01h	20h	Stores the VISCA device setting command.
Control command	02h	00h	Stores the control command.
Control reply	02h	01h	Stores the reply for the control command.

Pic.4 Payload Type Table

### k. Payload length

Stores the number of bytes (1 to 16) of data is stored on the payload.

Example: when the payload length is 16 bytes.

Byte 2:00h

Byte 3:10h

### l. Sequence number

The controller stores the sequence number that is added every time a message is sent. If the sequence number reaches the limit, next values will be 0. The peripheral device saves the sequence number in the message from the controller, and stores the sequence number of the received message corresponding to the message sent to the controller.

### m. Payload

Depending on the payload type, the following are stored.

- VISCA command
  - Stores the packet of the VISCA command.
- VISCA inquiry
  - Stores the packet of VISCA message.
- VISCA reply
  - Stores the reply for the command or inquiry (Acknowledge message, completion message, or error message).

- VISCA device setting command
  - Stores the packet of the VISCA device setting command.
- Control command
  - The following are stored on the payload division of the control command.

Name	Value	Description
RESET	01h	Resets the sequence number to 0. The value that was set as the sequence number is ignored.
ERROR	0Fyyh	yy=01: Abnormality in the sequence number.
		yy=02: Abnormality in the message (message type)

- Controlled reply
  - The following are stored on the payload division of the reply for the control command.

Message	Value	Description
Acknowledge	01h	Reply for RESET.

#### n. Delivery confirmation

VISCA over IP uses UDP as a communications protocol of the transport layer. Delivery of messages is not guaranteed for the UDP communication. Delivery confirmation and retransmission should be performed on the application.

When the controller sends a message to the peripheral device, wait until a reply for the message is received before sending the next message. You can confirm delivery of messages by managing the time-out waiting for a reply message sent.

If time out occurs on the controller, loss of one of the following message is considered:

- Command
- Acknowledge message
- Completion message for command

- Inquiry
- Reply message for the inquiry
- Error message
- Inquiry of the VISCA device setting command
- Reply message of the VISCA device setting command.

## 3PelcoD Internal Command List

Internal Command	Byte 1	Byte 2 (Address)	Byte 3	Byte 4	Byte 5	Byte 6	Byte 7	Comments
Right	0xFF	0x00 ~ 0xFF	0x00	0x02	0xVV	0xWW	Checksum	VV : Tilt speed 0x01 (low speed) to 0x18 (high speed)
Left	0xFF	0x00 ~ 0xFF	0x00	0x04	0xVV	0xWW	Checksum	
Up	0xFF	0x00 ~ 0xFF	0x00	0x08	0xVV	0xWW	Checksum	WW : Pan speed 0x01 (low speed) to 0x18 (high speed)
Down	0xFF	0x00 ~ 0xFF	0x00	0x10	0xVV	0xWW	Checksum	
Right - Up	0xFF	0x00 ~ 0xFF	0x00	0x0A	0xVV	0xWW	Checksum	
Left - Up	0xFF	0x00 ~ 0xFF	0x00	0x0C	0xVV	0xWW	Checksum	
Right - Down	0xFF	0x00 ~ 0xFF	0x00	0x12	0xVV	0xWW	Checksum	
Left - Down	0xFF	0x00 ~ 0xFF	0x00	0x14	0xVV	0xWW	Checksum	
Zoom Tele Down	0xFF	0x00 ~ 0xFF	0x00	0x30	0xVV	0xWW	Checksum	
Zoom Tele Up	0xFF	0x00 ~ 0xFF	0x00	0x28	0xVV	0xWW	Checksum	
Zoom Tele Left	0xFF	0x00 ~ 0xFF	0x00	0x24	0xVV	0xWW	Checksum	
Zoom Tele Right	0xFF	0x00 ~ 0xFF	0x00	0x22	0xVV	0xWW	Checksum	
Zoom Tele Up-Left	0xFF	0x00 ~ 0xFF	0x00	0x2C	0xVV	0xWW	Checksum	
Zoom Tele Up-Right	0xFF	0x00 ~ 0xFF	0x00	0x2A	0xVV	0xWW	Checksum	
Zoom Tele Down-Left	0xFF	0x00 ~ 0xFF	0x00	0x34	0xVV	0xWW	Checksum	
Zoom Tele Down-Right	0xFF	0x00 ~ 0xFF	0x00	0x32	0xVV	0xWW	Checksum	
Zoom Wide Down	0xFF	0x00 ~ 0xFF	0x00	0x50	0xVV	0xWW	Checksum	
Zoom Wide Up	0xFF	0x00 ~ 0xFF	0x00	0x48	0xVV	0xWW	Checksum	
Zoom Wide Left	0xFF	0x00 ~ 0xFF	0x00	0x44	0xVV	0xWW	Checksum	
Zoom Wide Right	0xFF	0x00 ~ 0xFF	0x00	0x42	0xVV	0xWW	Checksum	

Internal Command	Byte 1	Byte 2 (Address)	Byte 3	Byte 4	Byte 5	Byte 6	Byte 7	Comments
Zoom Wide Up-Left	0xFF	0x00 ~ 0xFF	0x00	0x4C	0xVV	0xWW	Checksum	
Zoom Wide Up-Right	0xFF	0x00 ~ 0xFF	0x00	0x4A	0xVV	0xWW	Checksum	
Zoom Wide Down-Left	0xFF	0x00 ~ 0xFF	0x00	0x54	0xVV	0xWW	Checksum	
Zoom Wide Down-Right	0xFF	0x00 ~ 0xFF	0x00	0x52	0xVV	0xWW	Checksum	
FOCUS Far Down	0xFF	0x00 ~ 0xFF	0x00	0x90	0xVV	0xWW	Checksum	
FOCUS Far Up	0xFF	0x00 ~ 0xFF	0x00	0x88	0xVV	0xWW	Checksum	
FOCUS Far Left	0xFF	0x00 ~ 0xFF	0x00	0x84	0xVV	0xWW	Checksum	
FOCUS Far Right	0xFF	0x00 ~ 0xFF	0x00	0x82	0xVV	0xWW	Checksum	
FOCUS Far Up-Left	0xFF	0x00 ~ 0xFF	0x00	0x8C	0xVV	0xWW	Checksum	
FOCUS Far Up-Right	0xFF	0x00 ~ 0xFF	0x00	0x8A	0xVV	0xWW	Checksum	
FOCUS Far Down-Left	0xFF	0x00 ~ 0xFF	0x00	0x94	0xVV	0xWW	Checksum	
FOCUS Far Down-Right	0xFF	0x00 ~ 0xFF	0x00	0x92	0xVV	0xWW	Checksum	
FOCUS Near Down	0xFF	0x00 ~ 0xFF	0x01	0x10	0xVV	0xWW	Checksum	
FOCUS Near Up	0xFF	0x00 ~ 0xFF	0x01	0x08	0xVV	0xWW	Checksum	
FOCUS Near Left	0xFF	0x00 ~ 0xFF	0x01	0x04	0xVV	0xWW	Checksum	
FOCUS Near Right	0xFF	0x00 ~ 0xFF	0x01	0x02	0xVV	0xWW	Checksum	
FOCUS Near	0xFF	0x00 ~ 0xFF	0x01	0x0C	0xVV	0xWW	Checksum	

Internal Command	Byte 1	Byte 2 (Address)	Byte 3	Byte 4	Byte 5	Byte 6	Byte 7	Comments
Up-Left								
FOCUS Near Up-Right	0xFF	0x00 ~ 0xFF	0x01	0x0A	0xVV	0xWW	CheckSum	
FOCUS Near Down-Left	0xFF	0x00 ~ 0xFF	0x01	0x14	0xVV	0xWW	CheckSum	
FOCUS Near Down-Right	0xFF	0x00 ~ 0xFF	0x01	0x12	0xVV	0xWW	CheckSum	
Stop	0xFF	0x00 ~ 0xFF	0x00	0x00	0x00	0x00	CheckSum	Stop Pan/Tilt & Zomm/Focus
Zoom Tele	0xFF	0x00 ~ 0xFF	0x00	0x20	0x00	0x00	CheckSum	Speed = VISCA Tele (Variable) = 0x03
Zoom Wide	0xFF	0x00 ~ 0xFF	0x00	0x40	0x00	0x00	CheckSum	Speed = VISCA Wide (Variable) = 0x03
Focus Far	0xFF	0x00 ~ 0xFF	0x00	0x80	0x00	0x00	CheckSum	Speed = VISCA Far (Variable) = 0x02
Focus Near	0xFF	0x00 ~ 0xFF	0x01	0x00	0x00	0x00	CheckSum	Speed = VISCA Near (Variable) = 0x02
$\text{CheckSum} = \text{Mod}((\text{Byte 2} + \text{Byte 3} + \text{Byte 4} + \text{Byte 5} + \text{Byte 6}), 0x100);$								

## 4PelcoD External Command List

### a. External Command

External Command	Byte 1	Byte 2 (Address)	Byte 3	Byte 4	Byte 5	Byte 6	Byte 7	Comments
Set Preset	0xFF	0x00 ~ 0xFF	0x00	0x03	0x00	0xpq	CheckSum	Memory Number( pq:0x00 To 0xFF)
Clear Preset	0xFF	0x00 ~ 0xFF	0x00	0x05	0x00	0xpq	CheckSum	
Goto Preset	0xFF	0x00 ~ 0xFF	0x00	0x07	0x00	0xpq	CheckSum	
POWER	0xFF	0x00 ~ 0xFF	0x00	0x45	0x00	On:0x01 Off: 0x02	CheckSum	Power On/Off
MENU	0xFF	0x00 ~ 0xFF	0x00	0x47	0x00	On:0x01 Off: 0x02	CheckSum	System Menu On/Off



External Command	Byte 1	Byte 2 (Address)	Byte 3	Byte 4	Byte 5	Byte 6	Byte 7	Comments
ENTER	0xFF	0x00 ~ 0xFF	0x00	0x49	0x00	0x00	Checksum	Menu Enter
BACKLIGHT	0xFF	0x00 ~ 0xFF	0x00	0x31	0x00	On:0x01 Off:0x02	Checksum	Back Light Compensation ON/OFF (* Enabled during AE Full Auto Mode)
MIRROR	0xFF	0x00 ~ 0xFF	0x00	0x4B	0x00	0x01:Normal 0x02:Mirror 0x03:Flip 0x04:Mirror+Flip	Checksum	Mirror Image ON/OFF & Picture flip ON/OFF
FREEZE	0xFF	0x00 ~ 0xFF	0x00	0x4D	0x00	On:0x01 Off:0x02	Checksum	Still Image ON/OFF
Auto Focus / Manual Focus	0xFF	0x00 ~ 0xFF	0x00	0x2B	0x00	AF:0x01 MF:0x02	Checksum	AF/MF Switch
Bright Ctrl Up	0xFF	0x00 ~ 0xFF	0x00	0xA1	0x00	0x00	Checksum	AE Bright Control Up
Bright Ctrl Down	0xFF	0x00 ~ 0xFF	0x00	0xA3	0x00	0x00	Checksum	AE Bright Control Down

## b. Query Command

Query Command	Byte 1	Byte 2 (Address)	Byte 3	Byte 4	Byte 5	Byte 6	Byte 7	Comments
<b>Query Command Package</b>								
Query Pan Position	0xFF	0x00 ~ 0xFF	0x00	0x51	0x00	0x00	Checksum	Get Pan Postion
Query Tilt Position	0xFF	0x00 ~ 0xFF	0x00	0x53	0x00	0x00	Checksum	Get Tilt Postion
Query Zoom Position	0xFF	0x00 ~ 0xFF	0x00	0x55	0x00	0x00	Checksum	Get Zoom Position
Query POWER	0xFF	0x00 ~ 0xFF	0x00	0x61	0x00	0x00	Checksum	Get Power On/Off Status
Query MENU	0xFF	0x00 ~ 0xFF	0x00	0x63	0x00	0x00	Checksum	Get Menu On/Off Status

Query Command	Byte 1	Byte 2 (Address)	Byte 3	Byte 4	Byte 5	Byte 6	Byte 7	Comments
Query BACKLIGHT	0xFF	0x00 ~ 0xFF	0x00	0x65	0x00	0x00	Checksum	Get Backlight On/Off Status
Query MIRROR	0xFF	0x00 ~ 0xFF	0x00	0x67	0x00	0x00	Checksum	Get Mirror & Flip Status
Query FREEZE	0xFF	0x00 ~ 0xFF	0x00	0x69	0x00	0x00	Checksum	Get Freeze Status
<b>Query Ack Package</b>								
Query Pan Response	0xFF	0x00 ~ 0xFF	0x00	0x59	0x00	0x00	Checksum	pqrz: Pan Position 0x0000 to 0x06A4 & 0xF95C to 0xFFFF (center 0000)
Query Tilt Response	0xFF	0x00 ~ 0xFF	0x00	0x5B	0x00	0x00	Checksum	pqrz: Tilt Position 0x0000 to 0x0384 & 0xFED4 to 0xFFFF (center 0000)
Query Zoom Response	0xFF	0x00 ~ 0xFF	0x00	0x5D	0x00	0x00	Checksum	pqrs: Zoom Position , pqrs: 0x0000~0x4000
Query POWER Response	0xFF	0x00 ~ 0xFF	0x00	0x71	0x00	On:0x01 Off: 0x02	Checksum	Power Status Response
Query MENU Response	0xFF	0x00 ~ 0xFF	0x00	0x73	0x00	On:0x01 Off: 0x02	Checksum	Menu Status Response
Query BACKLIGHT Response	0xFF	0x00 ~ 0xFF	0x00	0x75	0x00	On:0x01 Off: 0x02	Checksum	Backlight Status Response
Query MIRROR Response	0xFF	0x00 ~ 0xFF	0x00	0x77	0x00	0x01:Normal 0x02:Mirror 0x03:Flip 0x04:Mirror+Flip	Checksum	Mirror & Flip Status Response
Query FREEZE Response	0xFF	0x00 ~ 0xFF	0x00	0x79	0x00	On:0x01 Off: 0x02	Checksum	Freeze Status Response
Checksum = Mod((Byte 2 + Byte 3 + Byte 4 + Byte 5 + Byte 6), 0x100);								